

# TAIE

## Modular Miniature Digital PID Temperature / Process Controllers

### FA200 FA211 Series



Brand-new feelings - new release



Gray & Black colors

External Operating Box KA601 is used in FA200 parameter setting



PAT.NO. : M347603  
M347604  
M348972 (Taiwan)  
ZL200820301950.8  
ZL200820301949.5  
ZL200820301951.2 (China)

multinational patents



\* Match to RoHS System

# Modular Miniature DIN Rail installation single Loop

## FA200 FA211 Temperature & Process Controllers

Industrial Innovation

**FA200 Advance Type    FA211 Economic Type**

**Anit-traditional , Module Streamline style, Super-Miniature**

- DIN RAIL, Magnetic seat, 3 installation ways, Flexibly match the requests of outside panel board for Panel Board.
- High Reliability Modbus communication, Easily connect with HMI and PLC
- Supply free of charge of monitoring software, it is very convenient for short distance operation to remote control & parameter copy.
- Additional Copy function, correspond to parameter setting for a considerable assembly, Avoid the mistake and save much time
- Small volume, multi pieces assembly side by side, composed of multi points & circuit controllers instead of single loop & point control.
- Down lift and transparent cover design, easily open and avoid mistaking touch & operation
- Directly use and correspond to universal voltage AC100~240V without connecting external DC power and can save the cost
- There are two colors deep black and light gray that can be selected

### FA 200 Advance Type

- Plug in out terminal design is easy connection.
- External control box with double display has 7 segments display itself and can show PV value.
- New LED module design with 4 big digit display of PV & SV in control box is touched smoothly and can be plug in out and operate easily.
- The controller can be independently operated when the external control box is plug out from the controller After Parameter setting to prevent the man-made operating mistake.



### FA 211 Economic Type

- Reasonable prices, High reliability, replace traditional controllers, which should be need to hole to assemble.
- Single display design and keyboard operation directly.
- Down lift transparent cover design, Avoid mistaking touch & operation.



### Multi-Option of input & output

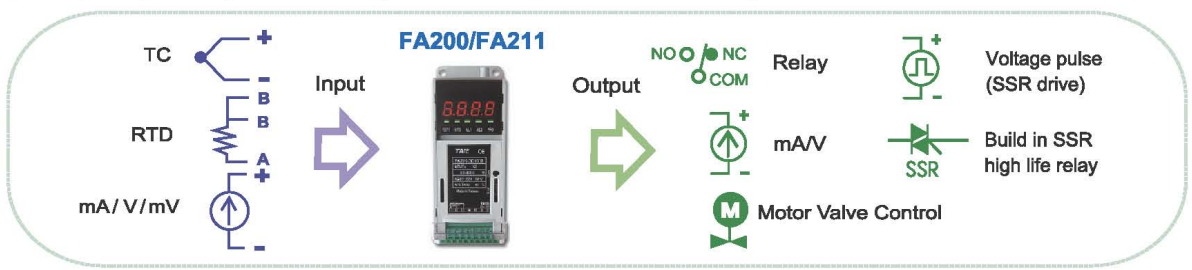

- Completely correspond to any kinds of input signal like Thermo couple, RTD PT100, and DC4~20mA. 0~5V.etc.
- Satisfy any requests for output mode like DC4~20mA, 0~5V Voltage, Current & the relay output of capacity 8A
- Provides with 3 features of Controller, Signal converter and Alarm monitor. It can change the signal of mV, V, RTD to the output of Voltage & Current 4~20mA instead of the signal converter.
- Separately design for signal circuit and power circuit on PC board, effectively restrain the external interference of electric wave.





**New-brand configuration design**

- Achieve whole set of module & miniaturization 40x107x43mm light and compact, save the space of panel .

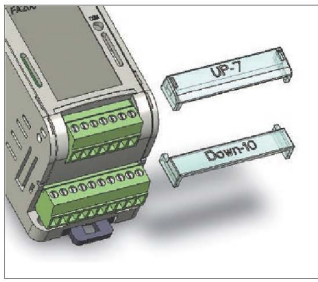
<p><b>DIN RAIL Installation</b></p> <ul style="list-style-type: none"> <li>● Provided with two installing ways of Din Rail &amp; Screw Lock, and suit for a Considerable quantities installation in the panel board. It is easy to install and take out controller itself.</li> </ul> 	<p><b>5 pcs LED Indicator</b></p> <ul style="list-style-type: none"> <li>● LED shows, alarm.control.output Watch the acts condition clearly</li> </ul> 	<p><b>Design of separating secure cover for terminal</b></p> <ul style="list-style-type: none"> <li>● Brand new design of secure cover for terminal with European standard</li> <li>● Terminal with power does not expose external and feel artistic and security.</li> </ul> 
---	--	---

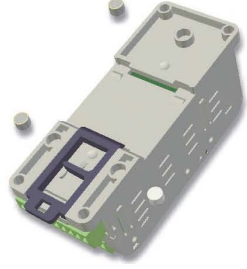
<p><b>compact module assembly design</b></p> <ul style="list-style-type: none"> <li>● Organization assembly.disassembles easily,extreme light.</li> <li>● Provided the advance SMT manufacturing system,high quality and high reliability.</li> </ul> 	<p><b>base attaches the magnetic place ( use for FA200)</b></p> <ul style="list-style-type: none"> <li>● Base attaches 3 magnets,may adsorb the made of iron box body willfully</li> <li>● Don't need to worry about fix it problem,suitable in the short period testing or gauging.</li> </ul> 
--	---

**Interval spacer design**

Controllers can be installing side by side through using the attached round interval stick to keep a distance between controllers to increase and assure the efficiency of heat release and control if there are some heating equipments or the using ambient temperature is higher.



Plug in the round interval stick on the up half of both side is available.

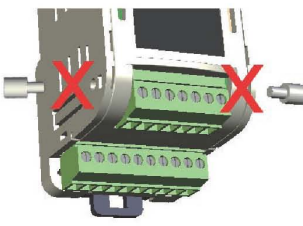

Do not plug in the round interval spacer on the down half of both side, avoid the efficiency of compensating for normal temperature.

**Optimize function**

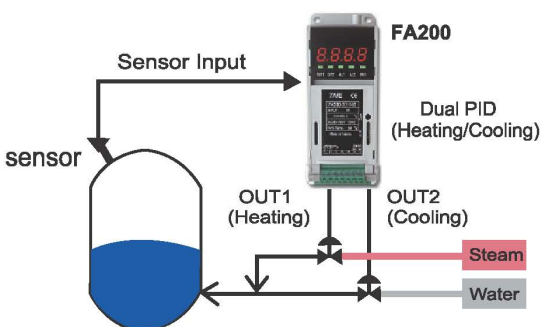
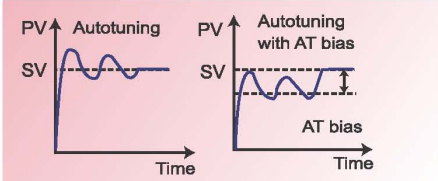
<p><b>Heating and Cooling Control</b></p> 	<p><b>PID autotuning control</b></p> <p>It will make to calculate optimize PID value.</p>  <p>When autotuning acts ,it will make PV hunting 1~2 cycle to calculate optimize PID value. To protect user's device , FA series controller can perform PV hunting below SV by setting AT bias value(ATVL) .</p>
---	---

Ultra intrepid.Option function

Transmission

FA controllers can use this function to transmit the PV or SV value to external device.

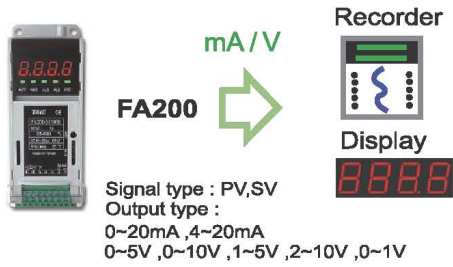

Remote SV

This function can use the external device to remote the FA controllers SV value.

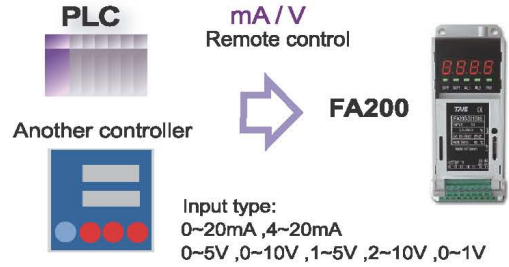

Motor Value Control

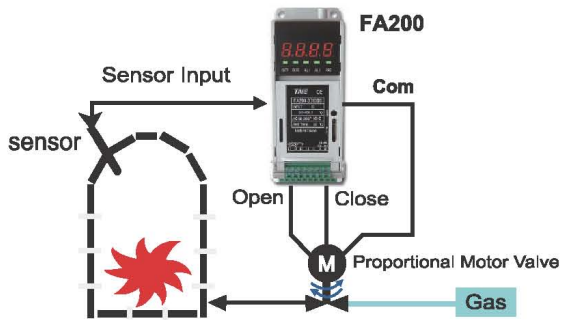

Ramp / Soak Program

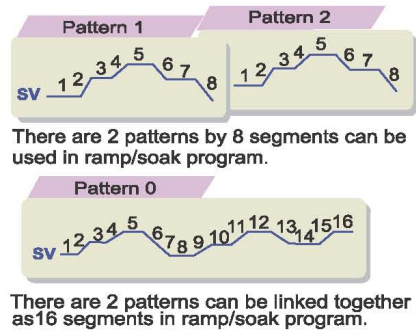

Big capacity terminal design

RELAY

SPST terminal with 8A  
SPDT terminal with 3A



SSR High life relay

Build in an additional high life of Relay (1A SSR), which is without terminal consumption, and suit for high frequency operation.



Maximum expanded

1 output 2 alarm or 2 output 1 alarm

Alarm Types

Alarm types list as below:

Deviation

- Deviation High Alarm
- Deviation Low Alarm
- Deviation High/Low Alarm
- Band Alarm

System

- System Failed Alarm
- System Normal Alarm
- Heater Break Alarm

PV

- PV High Alarm
- PV Low Alarm

Program

- Program Run Alarm
- Program End Alarm
- Segment End Alarm

HBA - Heater Break Alarm

Corresponding to the function of HBA under 100A. Two CT of 50A and 100A are available

Current rated range: 0.0~99.9A, Accuracy: 1% FS, Alarm terminal: AL1

Attached accessory CT: SC-80-T (holing diameter: 5.8mm, 0.0~50.0A) or SC-100-T (holing diameter: 12mm, 0.0~99.9A)

CT 50A

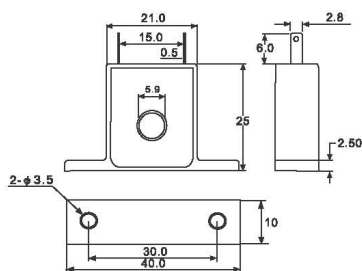

CT 100A

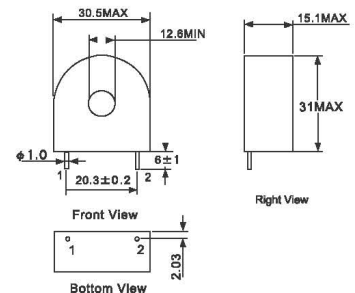



**Super Communication function of MODBUS (RTU,ASC II, TAIE)**

- It can be connected and controlled with any FA products which owned the communicated interface of MODBUS
- Easily connect HMI, PLC or connect PC monitor system
- To select the monitor mode by hour or day through MODBUS-RS485 communication software which TAIE supplied with free of charge
- All data can be saved in TXT or EXECL files
- All the saved data can be retrieved to use, and can be made as a reference of historical trend diagram

**Communication**

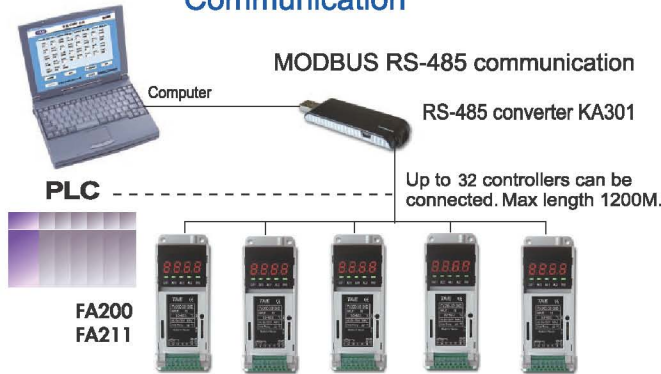

**Historical trend diagram**

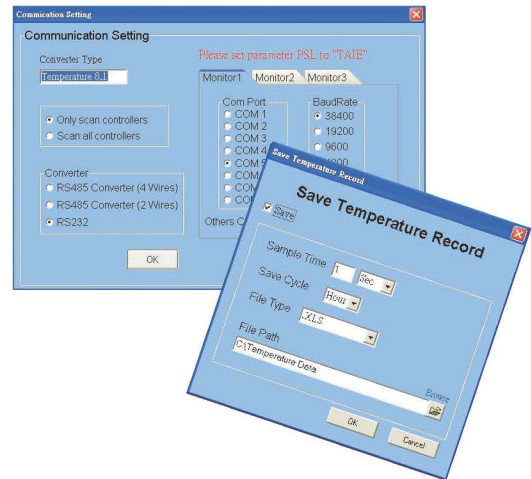
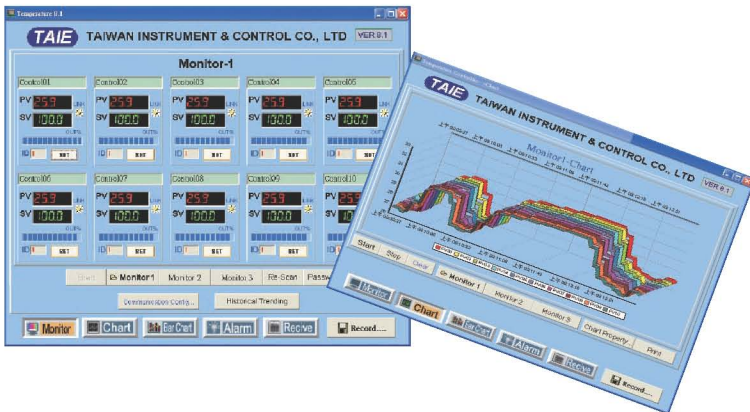
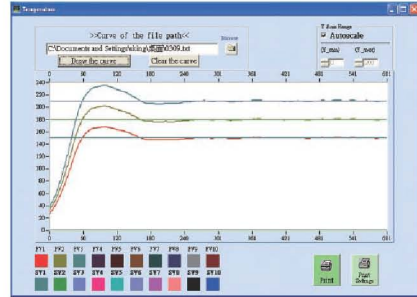

**New release**

**KA301 Universal Converter USB ↔ RS-485 / RS-422 / RS-232 / TTL**

- KA301 USB Converter is suitable for various of industrial equipments such as PLC.HMI.Inverters .Temperature controllers which provided the communicated interface like , RS-485/RS-422/RS-232 &TTL to communicate and condol with computer.
- KA301 provided 3 kind of converting connectors (KA502.KA504.KA503)and 3 kind of cables(CH-116.CH-117.CH-114)which are available for changing and extending use.

**Parameter copy function by USB interface**

- Using USB Converter (KA301) to communicate with PC, the data of master controller can be copied to another FA type controller.It can be saved a lot of time and avoid the parameter key-in mistake.
- KA301 USB communication converter uses DC5V power from computer. It can still copy the parameter even the controller without the power.



Monitor software for free

KA301 Converter (Option)

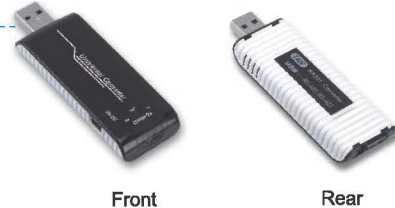

Front

Rear



connector

KA502  
RS-485/422

KA504  
RS-232

KA503  
Extend



CH-116

RS-485/422/232



Cable

CH-117

FX PLC use Only



CH-114

Extend

KA601 External Operating Box

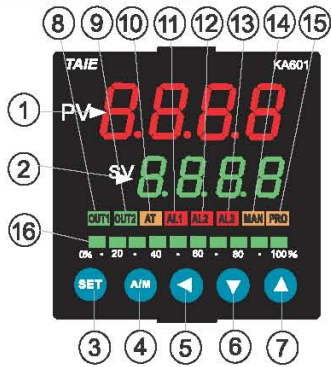

SYMBOL		NAME	FUNCTION
PV	①	Measured value (PV)display	Displays PV or various parameter symbols (Red)
SV	②	Setting value(SV)display	Displays SV or various parameter values (Green)
SET	③	Set Key	Pressing "SET" key before and after setting or shifting parameters to call up or save the setting value.
A/M	④	Auto/Manual Key	Switching between Auto (PID) and Manual output mode.
<	⑤	Shift Key	Shifting digits when settings are changed
∨	⑥	Down Key	Decrease the parameters or digit being modified *Program Hold <Only for programmable controller>
∧	⑦	Up Key (*Program Run)	Increase the parameters or digit being modified *Program run <Only for programmable controller>
OUT1	⑧	OUT1 lamp	Lights when OUT1 is on (Green)
OUT2	⑨	OUT2 lamp	Lights when OUT2 is on (Green)
AT	⑩	Autotuning lamp	Lights when Auto tuning is activated (Orange)
AL1	⑪	Alarm1 lamp	Lights when Alarm 1 is activated (Red)
AL2	⑫	Alarm2 lamp	Lights when Alarm 2 is activated (Red)
AL3	⑬	Alarm3 lamp	Lights when Alarm 3 is activated (Red)
MAN	⑭	Manual output lamp	Lights when manual output is activated (Orange)
PRO	⑮	*Program Running lamp	*Flashes when program running (Only for programmable controller)
OUT1%	⑯	OUT% Bar-Graph display	Output % is corresponded to display on 10-dot LED

Alarm mode

▲ SV ▲ Alarm set value

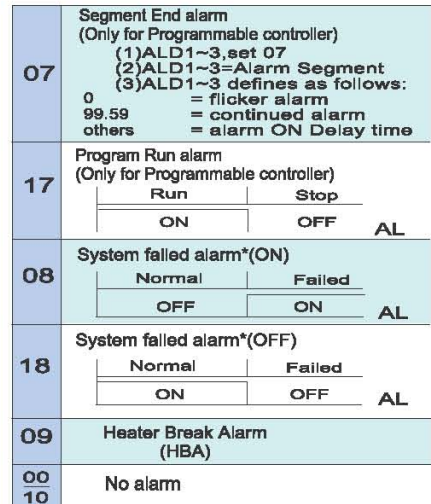
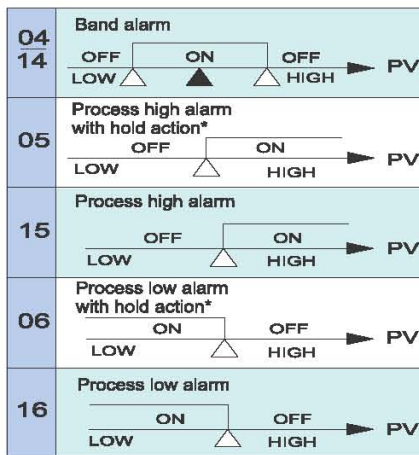
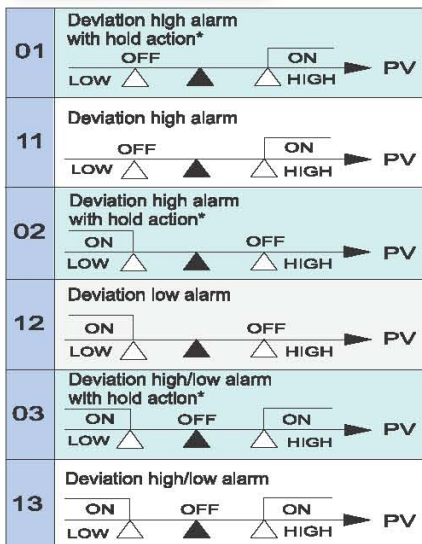

\* Hold action:

When Hold action is ON ,the alarm action is suppressed at start-up until the measured value(PV) enters the non-alarm range.

\* System failed:

It means that the controller display error message with one of following : "UUU1"or"NNN1"or"CJCE"

## Levels Explanation

### Levels Diagram

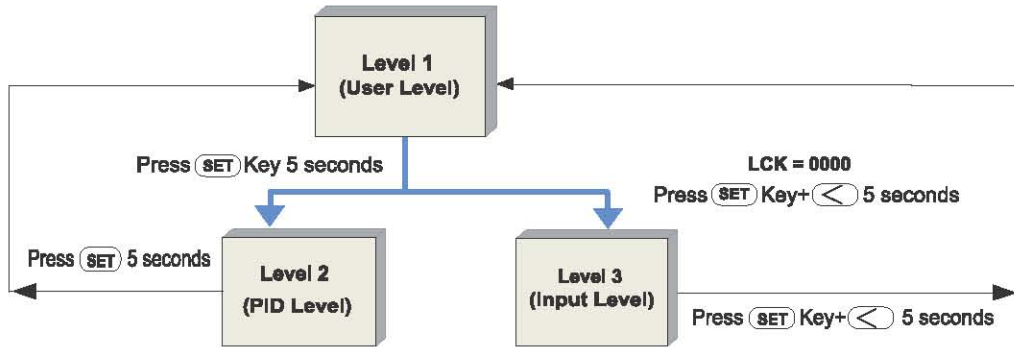

\* The controller returns to Level 1 if there is no key operation within 60 seconds.

\* In any Level, press **AM** key twice will return to Level 1.

## Levels in and out & Parameter Lock

Please enter in level 2 (PID level) to set the parameter LCK which can be changed

LCK	Levels entering available			Parameters which can be changed
	Level 1 (User Level)	Level 2 (PID Level)	Level 3 (Input Level)	
0000	Yes	Yes	Yes	All parameters (Factory set value)
1111	Yes	Yes	No	
0100	Yes	Yes	No	
0110	Yes	Yes	No	Parameters in Level 1
0001	Yes	Yes	No	SV" and "LCK"
0101	Yes	Yes	No	Only "LCK"

## Operations

### 1. Power ON:

Controller will display as following

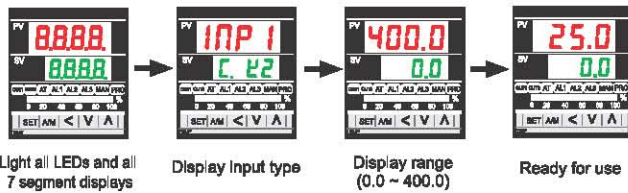

### 3. Autotuning (AT):

Use AT function to automatically calculate and set the optimize PID value for your system.

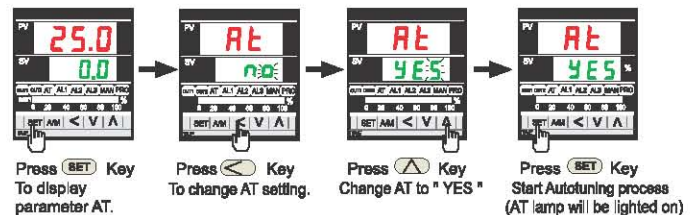

### 2. Change the Set Value (SV):

Change SV from 0.0 to 100.0

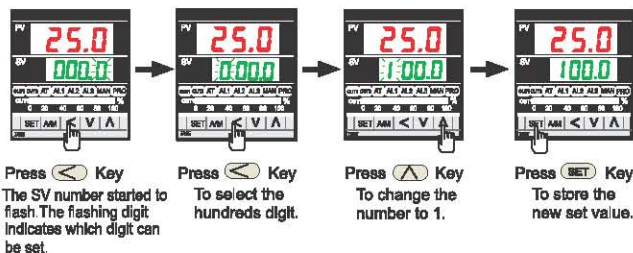

### 4. Change the Alarm value:

Change AL1 value to "5.0" (AL1 active, if PV exceeds SV over 5.0)

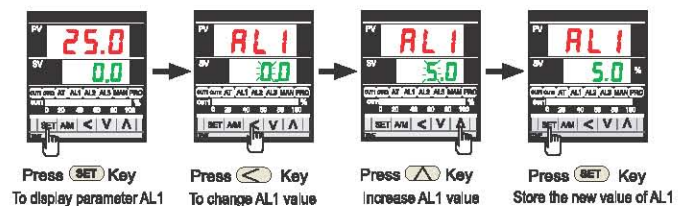

\* There are total 16 alarm mode types, referenced as below:

\* To change Alarm mode, press **SET** + **<** key 5 seconds to enter Level 3 (Input Level) and then change the value of ALD1/ALD2/ALD3.



## Terminal Wiring Diagram

### FA 200 Advance Type Plug-in-out Pitch 3.5 mm

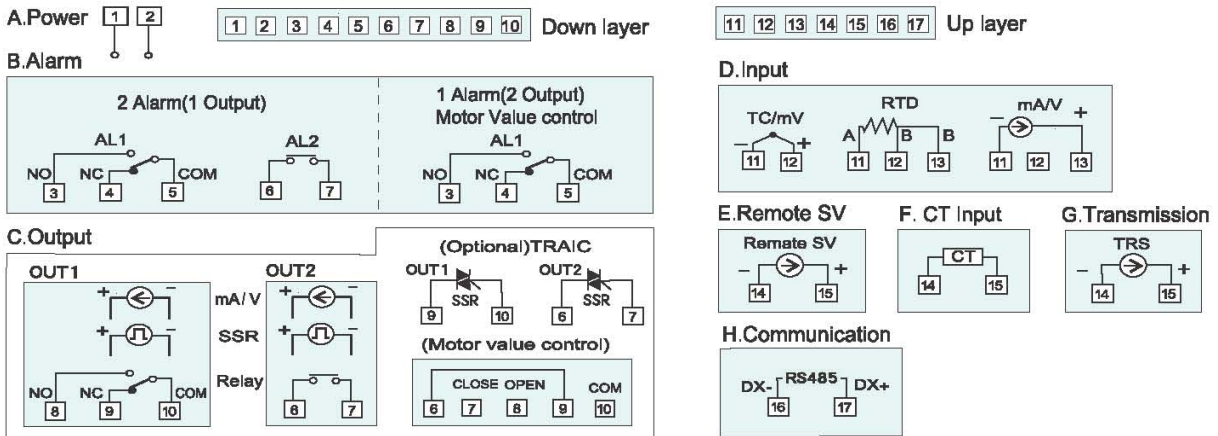

### FA 211 Economic Type Fixed Pitch 5.0 mm

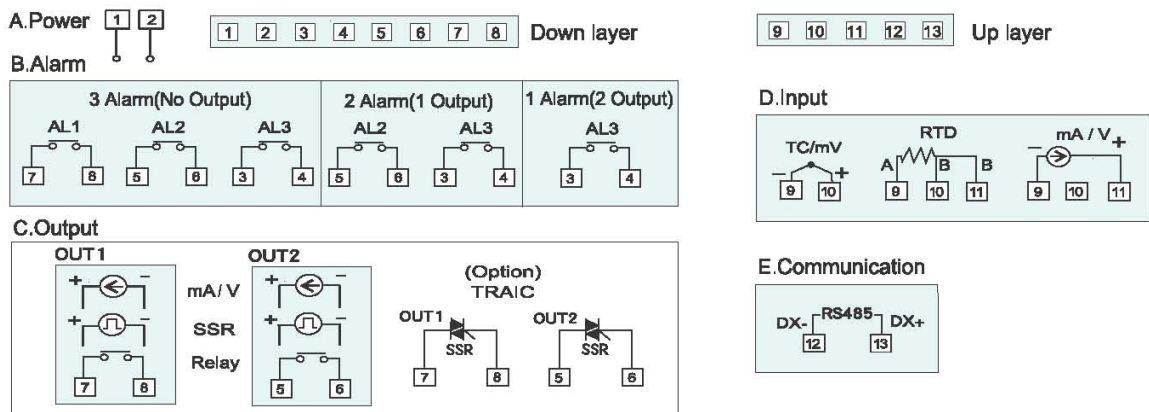

## Outer Dimension

Unit:mm

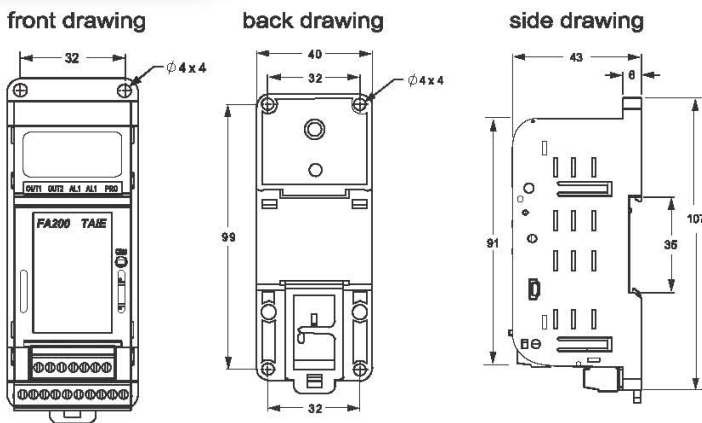

### DIN rail Dimension (reference)

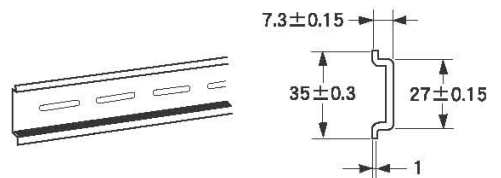

## Assembly

When assembling, plug in FA200 on DIN rail and then lodge the bottom in easily.



When taking out of FA200, insert into the square hole on the bottom of FA200 with driver and put front and then it can be taken out from DIN rail.

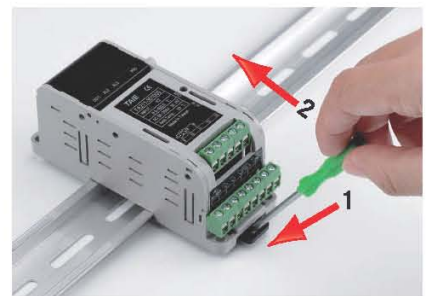





Standard Spec.			
Model	Advance Type FA200	Economic Type FA211	
outer case color	two colors of deep black & light gray are available		
Wiring terminal	Plug in out terminal	fixed terminal	
Parameter setting	by external control box or by communication	build in 4 operating keys or by communication	
Assembly	DIN rail, M4 screw hole, magnetic seat	DIN rail or M4 screw hole	
Display	External control box with double display + PV single display	single display	
Standard accessories	1 Output + 1 Alarm		
maximum expansibility	1 Output + 2 Alarms or 2 Outputs + 1 Alarm		
additional option	programmable 2 patterns by 8 segments	Yes (Option)	YES (Option)
	High life SSR	Yes (Option)	YES (Option)
	communication	Yes (Option)	YES (Option)
	Motor Valve Control	Yes (Option)	No
	TRS	Yes (Option)	No
	Remote SV	Yes (Option)	No
	Heater Break Alarm (HBA)	Yes (Option)	No
General Spec.			
Supply Voltage	AC 85-265V		
Frequency	50 / 60 HZ		
Power Consumption	Approx 4VA		
Data Protection	EEPROM, Endurance : 1 Million write cycles, Data Retention : 10 years		
Isolated resistance	main loop -case(ground) ~ control loop - case(ground) DC500V > 10MΩ		
Dielectric Strength	main loop -case(ground) AC 1500V 1min / control loop - case(ground) AC 1000V 1min		
Vibration Endurance	10~55HZ 0.5mm (MAX 2G) XYZ various direction 2h		
Assault Endurance	100m/s <sup>2</sup> (Approx 10G) XYZ various direction 3 times		
Protection Configuration	IP00		
Display Height of Control box	LED Module PV : 14mm SV : 10mm	without control box	
Display Height of single range LED	7 section digital display : 7mm		
Dimension	40 x 107 x 43 mm		
Weight	Appro x 115g		
Operating Ambient temperature	0~50°C		
Operating Ambient humidity	correspondent humidity 20-90% RH without dew		
Reserved Temperature	-25°C ~ + 65°C		
Control Features			
Control method	Heating, Cooling single output or Heating & Cooling both output PID, PI, PD, P, ON/OFF (P=0), FUZZY		
PID Parameter	P : 0.0 - 200.0% I : 0 ~ 3600 sec. D : 0 ~ 900 sec.		
Control Cycle	0~150 sec.		
Input Features			
Input	the point of signal point	1 point	
	Accuracy	0.2 % Full Scale ± 1digit	
	Sample time	250 ms	
	TC	K, J, R, S, B, E, N, T, W5Re/W26Re, PL11, U, L	
	RTD	PT100, JPT100	
	mA (DC)	4-20mA, 0-20mA	
	Voltage (DC)	0-1V, 0-5V, 0-10V, 1-5V, 2-10V, -10-10mV, 0-10mV, 0-20mV, 0-50mV, 10-50mV	
	DP Position Option 0000 000.0 00.00 0.000	When using the input of sensor signal, DP position for PV can be selected the sensor code No. 1~ 52 When using the input of DC mA or Voltage, DP position for PV can be selected code No. 61 ~96 by DP Parameter.	
Output Features			
Output 1	Relay	Advance Type FA200	Economic Type FA211
	for external SSR drive 4-20mA / 0-20mA 0-5V, 0-10 V SSR high life relay	SPDT type (a point 8A, b point 3A 220V) ON : 24V, OFF : 0V, Max. load current 20mA Max. load resistance 560 Ω Max. load current 20mA 1A TRIAC SSR (Option)	SPST type (1a point 8A 220V)
Output 2	Relay	SPST type 8A 220V	
	for external SSR drive 4-20mA / 0-20mA 0-5V, 0-10 V High life relay	ON : 24V, OFF : 0V, Max. load current 20mA Max. load resistance 560 Ω Max. load current 20mA 1A TRIAC SSR (Option)	
Communications			
Interface	RS-485 two wires Half Duplex		
Protocol	Modbus RTU ~ Modbus ASCII ~ TAIE		
Data bit	8 bit		
Start bit	1 bit		
Stop bit	1 bit or 2 bit		
Baud rate	38400 ~ 19200 ~ 9600 ~ 4800 ~ 2400 bps *		
Error examine	Parity even ~ odd or CRC-16 ( in Modbus)		
Connective pieces	Maximum 32 pcs		
Communicate range	Maximum 1200 m		
Alarms			
Alarm 1 Relay	SPDT type (a point 8A, b point 3A 220V)	SPST type 1a point 8A 220V	
Alarm 2 Relay	SPST type 8A 220V		
Alarm setting range	-1999~9999 (Dot positions are different depended on the various Input Types)		



Order Information

★ Factory basic value : FA200-101000-02A FA211-101000-02A

Model	Output 1	Output 2	Alarm	Transmission	Remote SV	Communication	Input Type	Power
<b>FA 200</b> PFA 200 (Programmable) Plug-in-out terminal (Advance Type)	1	0	1	0	0	0	02	A
<b>FA 211</b> PFA 211 (Programmable) (Economic Type)	0 None 1 (Relay) 2 Voltage Pulse (SSR Drive) 3 4~20mA 4 0~20mA A 0~5V B 0~10V C 1~5V D 2~10V T TRIAC (SSR) 7 Motor value control	0 None 1 (Relay) 2 Voltage Pulse (SSR Drive) 3 4~20mA 4 0~20mA A 0~5V B 0~10V C 1~5V D 2~10V T TRIAC (SSR)	0 None 1 1Set 2 2Sets A HBA B HBA+AL2	0 None 1 4~20mA 2 0~20mA A 0~5V B 0~10V C 1~5V D 2~10V	0 None 1 4~20mA 2 0~20mA A 0~5V B 0~10V C 1~5V D 2~10V	0 None B RS-485 MODBUS	See Input Codes	A AC 85~265V

★ Factory set value K2, code 02  
 ★ TC Input(K, J, R, S, B, E, N, T, W, PL1, U, L...) setting, can be changed to any types by user  
 ★ RTD(JPT 100, PT100) setting, can be changed to any type by user  
 ★ TC, RTD, LINEAR can be changed each other but need to change the parts of hardware. For more details, please contact local agents.

★ Above green blocks are optional functions with additional agents.

Function Option

★ Maximum expand is 1 Output 2 Alarm or 2 Output 1 Alarm  
 ★ "HBA" & "Remote" function can not be selected at the same time.

Type	RAMP/SOAK PROGRAM	Communication	★Output 1		★ Output 2	★ Alarm 2	HBA	Transmission	Remote SV
			Motor value control	TRIAC SSR					
FA 200	Yes	Yes	Yes	Yes	Yes	Yes	Yes	Yes	Yes
FA 211	Yes	Yes	No	Yes	Yes	Yes	No	No	No

Input Types

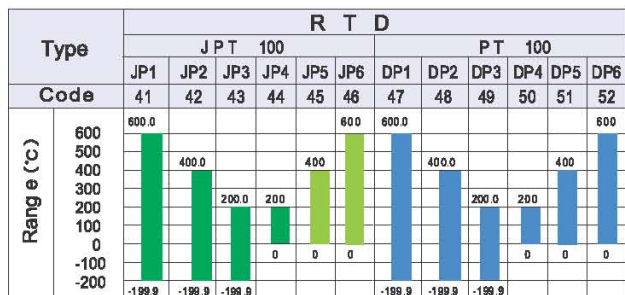
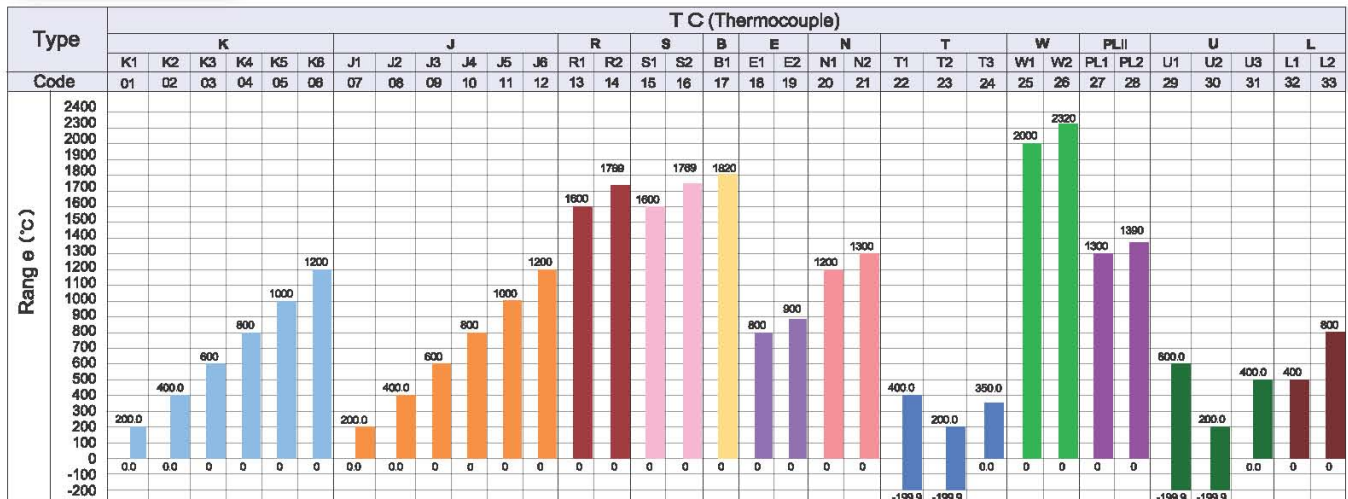

Distributor

Type	LINEAR																
	AN1			AN2	AN3	AN4				AN5							
Code	61	62	63	64	71	76	81	82	83	84	85	86	87	91	92	93	94
Input Range	-10~10mV	-2~2V	-5~5V	-10~10V	0~10mV	0~20mV	0~50mV	0~20mA	0~1V	0~5V	0~10V	0~5KΩ	0~2V	10~50mV	4~20mA	1~5V	2~10V
Set Range	Four kinds of choices: -1999~9999 -199.9~999.9 -19.99~99.99 -1.999~9.999																