

Dimensions (mm)

**Standalone model**

•D2RF-T□  
•D2GF-T□

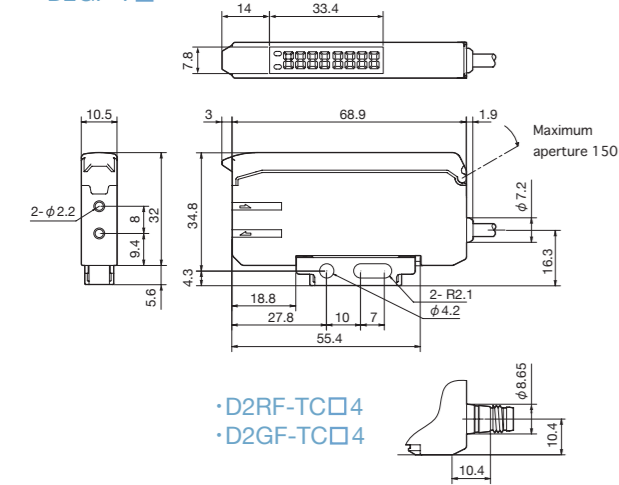

•D2RF-TC□4  
•D2GF-TC□4

•D2RF-2T□  
•D2GF-2T□

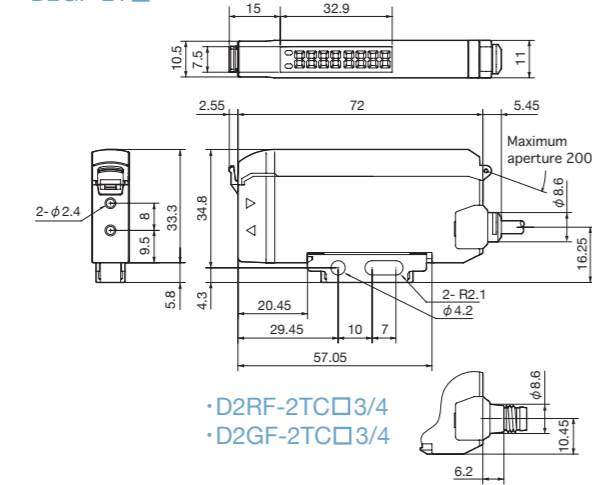

•D2RF-2TC□3/4  
•D2GF-2TC□3/4

**Interconnect model**

•D2□F-TM  
•D2□F-TMC□4

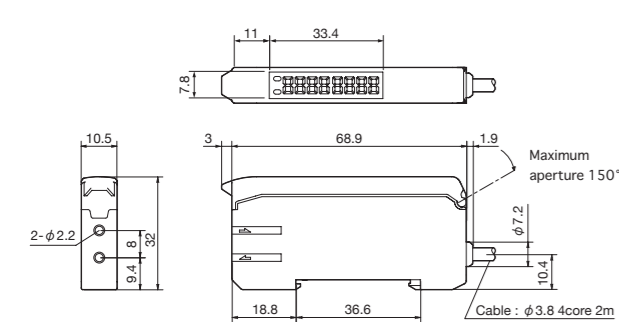

•D2□F-TS□  
•D2□F-TSC□4

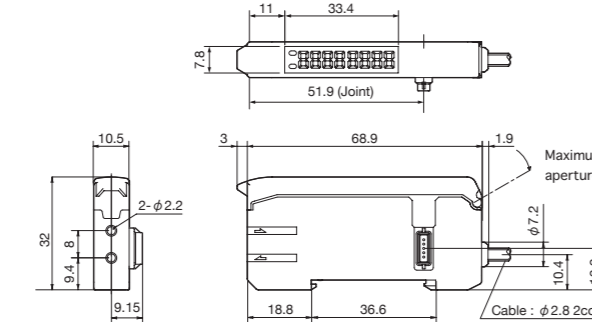

•M8 Connector type



**Analogue model**

•D2RF-TA□

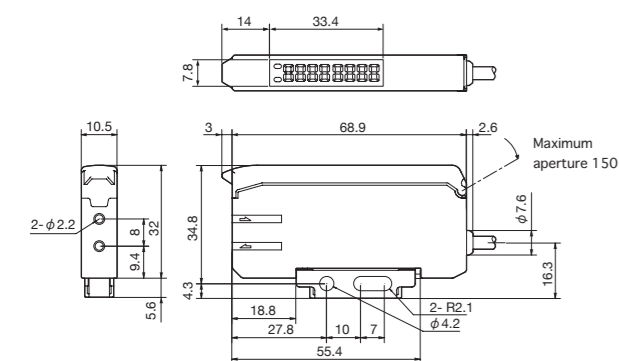

•D2RF-2TA□

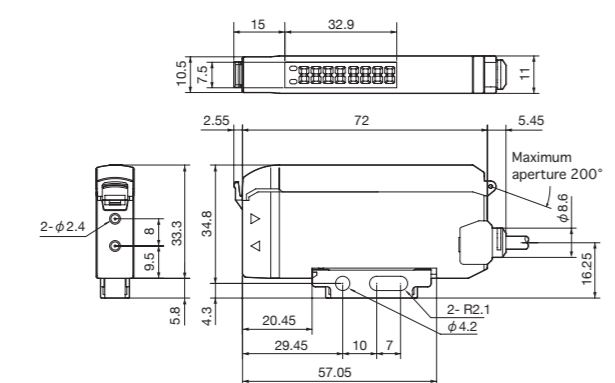

- Specifications and technical information not mentioned here are written in Operation Manual. Or visit our website for details.
- All the warnings and cautions to know prior to use are given in Operation Manual.

Digital Fiber Amplifier  
**D2RF-T Series**

**Standard Type : Stand-alone use**

<b>(IP50 protection)</b>	
D2RF-TN/TP	2 meter cable
D2RF-TCN3/TCP3	M8 QD, 3 pin
D2RF-TCN4/TCP4	M8 QD, 4 pin
<b>(IP66 protection)</b>	
D2RF-2TN/2TP	2 meter cable
D2RF-2TCN3/2TCP3	M8 QD, 3 pin
D2RF-2TCN4/2TCP4	M8 QD, 4 pin

**Standard Type : Interconnection use**

<b>(IP50 protection)</b>	
D2RF-TMN/TMP	Master Unit
D2RF-TSN/TSP	Slave Unit
D2RF-TMCN4/TMCP4	Master Unit, M8 QD
D2RF-TSCN4/TSCP4	Slave Unit, M8 QD

**Mark Sensor Type : Stand-alone use**

<b>(IP50 protection)</b>	
D2GF-TN/TP	2 meter cable
D2GF-TCN3/TCP3	M8 QD, 3 pin
D2GF-TCN4/TCP4	M8 QD, 4 pin
<b>(IP66 protection)</b>	
D2GF-2TN/2TP	2 meter cable
D2GF-2TCN3/2TCP3	M8 QD, 3 pin
D2GF-2TCN4/2TCP4	M8 QD, 4 pin

**Analogue Type : Stand-alone use**

<b>(IP50 protection)</b>	
D2RF-TAN/TAP	4-20mA Analog / Transistor output
<b>(IP66 protection)</b>	
D2RF-2TAN/2TAP	4-20mA Analog / Transistor output

Digital Fiber Amplifier with Two Independent Outputs.  
High speed 60 micro second response.



Lead-free construction conforms to new RoHS standards.

The D2RF Digital Fiber Amplifier is equipped with the latest functions and features to meet even the most demanding needs of today's industry.



### APC Function (Auto Power Control)

The APC function ensures precise sensing even when there are changes in the temperature or environmental conditions. APC maintains a constant power level of light emission by regulating the current flow into the light emission element. The APC function can be turned On and Off.

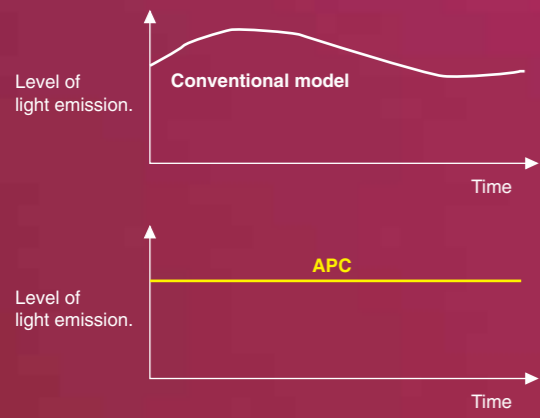

### IP66 and IP50, two types.

If your application is around water or high humidity. There is a model of the D2RF-T series with an IP66 rating.



### SAM Circuit - The ASC function (Auto Sensitivity Control)

Our engineer "SAM" designed this function. The lens and/or reflector may be contaminated over time. The D2RF amplifier monitors the change in light level and automatically resets the threshold value.

After cleaning off the lens / reflector it used to be necessary to reset the threshold setting. The D2RF does not require this step. Simply clean off the lens and wait three seconds without a target present. The sensor will automatically reset the threshold level for the change. This is how the SAM circuit works.

After cleaning the incoming light level will increase suddenly. The SAM circuit computes the preset threshold based on the increase in light intensity. This function is available only in Transparent Detection Mode.

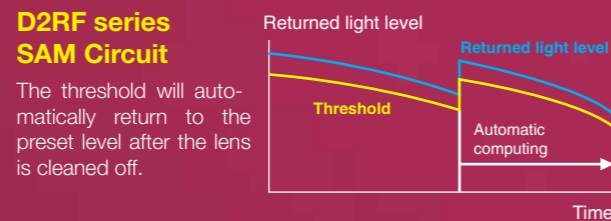
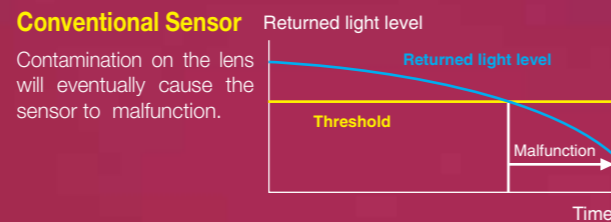

### Two four digit display's.

Received Light Level and Threshold Setting

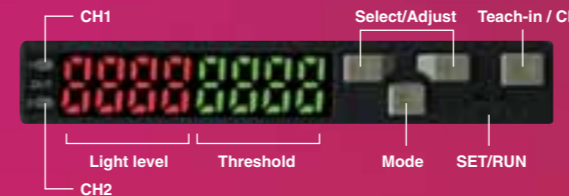

### Long Term Stable Detection.

A conventional 3 element LED will lose brightness over time. This results in a decrease in sensitivity in the sensor. Optex FA's new D2RF uses a 4 element LED to provide long service life. The Green LED type D2GF uses a "Glan N2" LED, which offers the best performance for Mark Detection with a Green LED light source.

### 60 micro second high speed response.



Both outputs can be set to operate at this speed. This response time is available in 5 of the teach modes

### Two Independent Outputs. Each output can be set separately.

The 2nd output can be configured as an external Teach input.

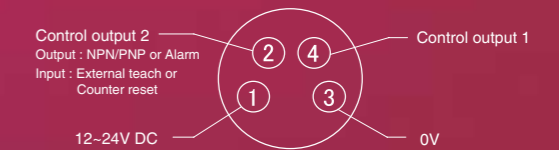
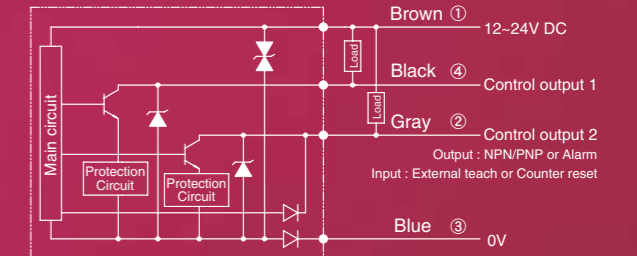

The operation of each output can be set to Light-On / Dark-On. Also, the Threshold level, Timer settings, etc. of each output can be set independently. The Analog output type (D2RF-TAN/P) provides a 4 ~ 20 mA (gray wire) analog output and a NPN (or PNP) digital output (black wire).

The second output can be configured as an Alarm output (self-diagnostic). It can also be set to operate as an External Teach Input or Counter Reset Input if the Counter function is being used.

### 6 teach method for individual applications.

#### Full Power Teaching

Standard detection mode for Thru-beam type sensing but applicable for retro-reflective sensing also.



#### Full automatic Teaching

Set while the equipment is operating.



#### Single point Teaching

Set without a target present.



#### Transparent / Glass Teaching

Ideal for the detection of glass, film, plastic or any transparent material.



#### Two points Teaching

Standard detection mode for Diffuse type sensing. It is possible to make fine adjustments.



#### Zone Teaching

Similar to Area Teach Mode. This is useful if the conveyor moves closer to and farther from the sensor. An area +/- 10% of the teach point can be detected.

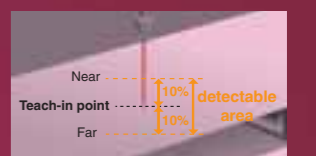





## LED Power adjustment - 3 step adjustment of LED emitting power.

A highly reflective target will cause the amplifier to saturate making adjustment difficult. This can also happen if the fiber cable is mounted too close to the target.

In situations where the amplifier is saturated due to excessive reflected light, the power level of the emitting LED can be decreased to 50 or 25 percent.

### Power setting

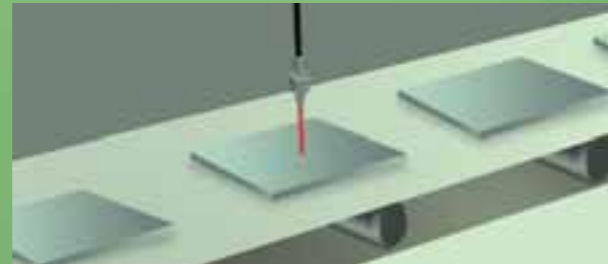

## Differential Sensing Mode

A bumpy conveyor always makes stable detection difficult. The D2RF-T solves this problem with the Differential Sensing Mode. The Master and Slave amplifiers will calculate the difference between the reflection from the background and the target (see picture below). No matter how much the surface of the conveyor moves up and down the D2RF-T can follow the change and reliably detect the target.

### Operation Flow:

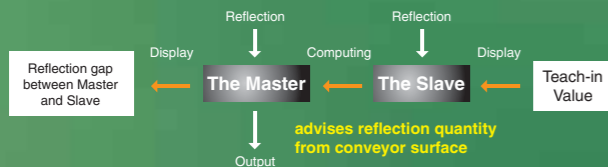

### How to follow the changing condition!

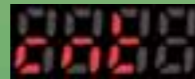
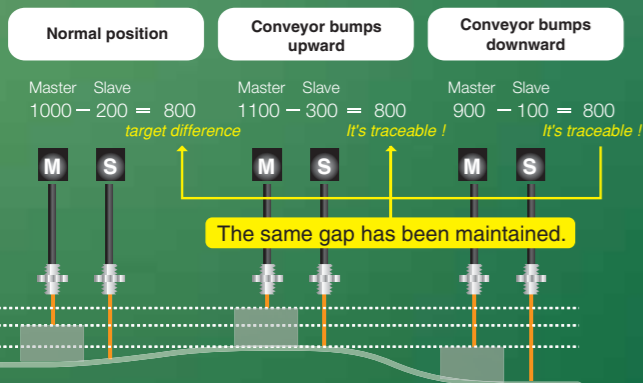

## Counter Mode

The D2RF amplifier features a built-in counter. This makes it convenient to count parts, for example 10 pcs. in a bag. The output turns on once the sensor has counted the desired quantity. Simply program in the number of parts to count.

### Normal Mode:

An output comes as the sensor counts.

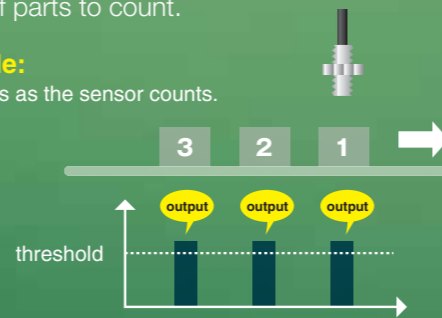

### Counter Mode:

An output comes only when the preset numbers are counted. (Max 9999)

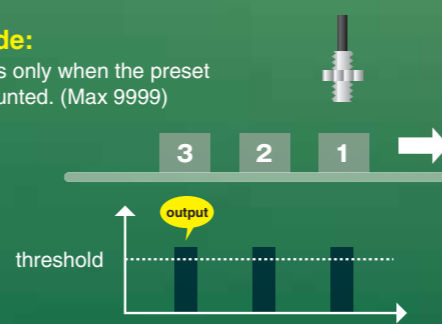

## Automatic Tuning

This provides a way to boost or dampen the excess gain level of the amplifier in poor sensing conditions (low light level, low sensitivity or saturating condition). Automatic Tuning is ideal when you need a little bit better excess gain level, or when detecting a dark object with diffuse reflective fiber cables.



## Selectable Response Time

The Response time will affect the sensing distance. The D2RF-T has three choices (Long, Standard, and Fast), select the response time based on the required sensing distance.

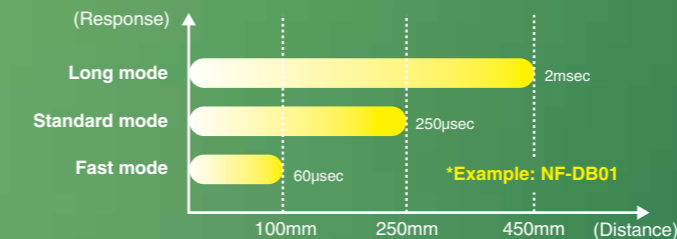

Long Mode boosts the power for the maximum sensing distance with a 2 msec. response time. The Fast Mode has a reduced sensing distance but provides high speed 60µsec. response.



## Edge Sensing

The sensor output triggers when there is a sudden increase or decrease in the light level. This is ideal for sensing objects without being influenced by a dusty environment.

### Rising Edge Sensing Mode



### Falling Edge Sensing Mode



## One Shot Setting

The settings from the Master amplifier can be copied into all of the Slave amplifiers in a single step. It's easy, simply push the button once. No other accessory is required.

### The Master amplifier can be followed by up to 7 Slave amplifiers

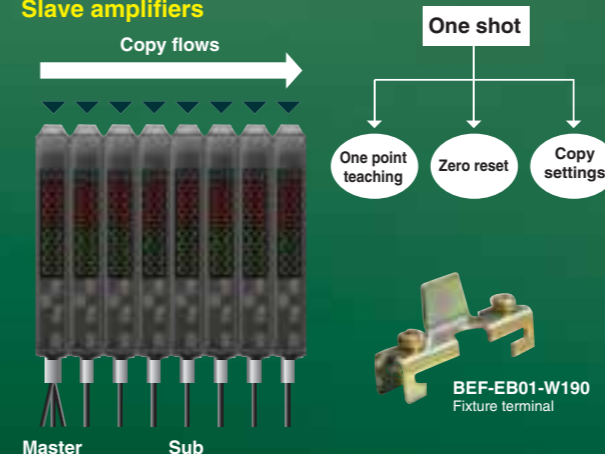

Any amplifier that has the lock function enabled will not be changed



## Zero Reset

The sensor display can be reset to zero. This is useful for adjusting the display's of the Master and Slave units to read the same. It is also good to set the value to zero when the light is interrupted.

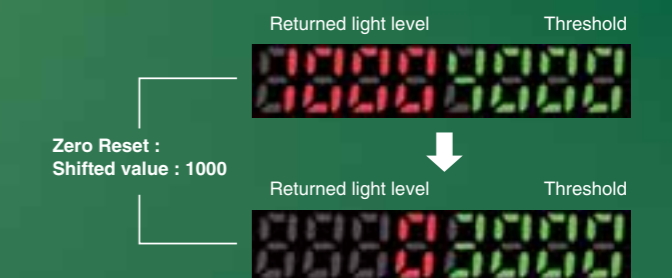

## Cross Talk Prevention

The amplifier frequencies are automatically set between the Master and Slave units. Cross talk prevention is possible for up to 4 amplifiers.



## External Teach Input (CH2)

It is possible to have a Remote Teach Input if the CH2 output is re-assigned as an input. When using the Remote Teach with Interconnected amplifiers all units will perform the Teach function simultaneously. (This function is not available for Analogue Type)

# Specification

Type	Standard	Mark sensor	Analogue	
<b>Stand-alone Type</b>				
<b>IP50 type</b>	Cable type NPN / PNP	D2RF-TN, or D2RF-TP	D2GF-TN or D2GF-TP	D2RF-TAN or D2RF-TAP
	M8 QD 4pin, NPN / PNP	D2RF-TCN4 or D2RF-TCP4	D2GF-TCN4 or D2GF-TCP4	NA
<b>IP66 type</b>	Cable type NPN / PNP	D2RF-2TN, or D2RF-2TP	D2GF-2TN or D2GF-2TP	D2RF-2TAN or D2RF-2TAP
	M8 QD 4pin, NPN / PNP	D2RF-2TCN4 or D2RF-2TCP4	D2GF-2TCN4 or D2GF-2TCP4	NA
M8 QD 3pin, NPN / PNP	D2RF-2TCN3 or D2RF-2TCP3	D2GF-2TCN3 or D2GF-2TCP3	NA	
<b>Interconnection Type</b>				
<b>Master unit</b>	Cable type NPN / PNP	D2RF-TMN, or D2RF-TMP	D2GF-TMN, or D2GF-TMP	NA
	M8 QD 4pin, NPN / PNP	D2RF-TMCN4, or D2RF-TMCP4	D2GF-TMCN4, or D2GF-TMCP4	NA
<b>Slave unit</b>	Cable type NPN / PNP	D2RF-TSN, or D2RF-TSP	D2GF-TSN, or D2GF-TSP	NA
	M8 QD 4pin, NPN / PNP	D2RF-TSCN4, or D2RF-TSCP4	D2GF-TSCN4, or D2GF-TSCP4	NA
<b>Light Source</b>	Red LED	Green LED	Red LED	
<b>Response Time</b>	60 micro sec (Fast mode), 250 micro sec (standard), 2.0 ms (Long distance)			
<b>Auto Control System</b>	APC / ASC			
<b>LED Power Control</b>	3 steps ; 100%, 50% and 25%			
<b>Timer Functions</b>	On delay/Off delay /One shot, 1-9,999msec (1msec increment)			
<b>Sensitivity Adjustment</b>	Teach-in + fine adjustment			
<b>Output Indicator</b>	Output (orange) : 1CH / 2CH common	Output (orange)		
<b>Digital Indicator</b>	7 segment LED, 4 digits in Red, 4 digits in Green			
<b>Teach-in Mode</b>	Full Power / One point / Two points / Full Automatic / Differential / Zone / Transparent			
<b>Control Output</b>	2CH, NPN or PNP open collector, DC30V, 100mA Max	1CH, NPN or PNP		
<b>Analogue Output</b>	NA	4-20mA		
<b>Parallel Installation</b>	Up to 16 sets			
<b>Crosstalk Prevention</b>	Up to 4 sets			
<b>Output Mode</b>	Light on / Dark on selectable			
<b>Sensing Mode</b>	Long Distance Mode, Standard, Fast mode,			
<b>Display</b>	Regular display plus ; bar, %, eco (off, run mode only)			
<b>External Input</b>	Teaching / Counter Reset			
<b>Supply Voltage</b>	DC 10-24V +/- 10% ripple			
<b>Current Consumption</b>	45mA Max (24V)			
<b>Circuit Protection</b>	Reverse Polarity, Overcurrent, Short circuit			
<b>Warmup Time</b>	100m sec			
<b>Ambient Temp/Humidity</b>	-25 to 55 C, 35 to 85% RH			
<b>Storage Temp/Humidity</b>	-40 to 70 C, 35 to 85% RH			
<b>Ambient Illumination</b>	Sunlight 10,000 lux, High Frequency Lamp 3,000 lux			
<b>Protection Category</b>	IEC, IP50 (except Stand-alone IP66 types)			
<b>Noise Resistance</b>	IEC, CE			
<b>Shock Resistance</b>	IEC 68, 50G			

Specifications are subject to change without prior notice.

# D2RF Sensing Distance

## Diffuse Reflective Type

Type	Distance on Response			Radius	Object	
	60µs	250µs	2ms		Regular	Minimum

Standard						
NF-DM01	100	250	400	R25	White 90% 350x350mm	ø0.15mm
NF-DT03	30	60	100	R15	White 90% 350x350mm	ø0.15mm
NF-DS06	30	60	100	R15	White 90% 350x350mm	ø0.15mm
NF-DK06	100	250	400	R25	White 90% 350x350mm	ø0.15mm
NF-DK04	100	250	400	R25	White 90% 350x350mm	ø0.15mm

Coaxial						
NF-DB01	100	250	450	R25	White 90% 350x350mm	ø0.15mm
NF-DB03	100	250	450	R25	White 90% 350x350mm	ø0.15mm
NF-DB01-10	50	120	250	R25	White 90% 350x350mm	ø0.15mm
NF-DT01	50	120	250	R15	White 90% 350x350mm	ø0.15mm
NF-DM02	50	120	250	R15	White 90% 350x350mm	ø0.15mm
NF-DK23	100	250	450	R25	White 90% 350x350mm	ø0.15mm
NF-DK21	15	40	70	R15	White 90% 350x350mm	ø0.15mm

Super Flexible						
NF-DK66	80	180	300	R2	White 90% 350x350mm	ø0.15mm
NF-DK67	80	180	300	R2	White 90% 350x350mm	ø0.15mm
NF-DK04Z	80	180	300	R2	White 90% 350x350mm	ø0.15mm
NF-DK63Z	80	180	300	R2	White 90% 350x350mm	ø0.15mm

Flexible						
NF-DR01	80	200	350	R4	White 90% 350x350mm	ø0.15mm
NF-DR02	15	30	70	R4	White 90% 350x350mm	ø0.15mm
NF-DR03	25	50	120	R4	White 90% 350x350mm	ø0.15mm
NF-DR04	15	30	70	R4	White 90% 350x350mm	ø0.15mm
NF-DR06	25	50	120	R4	White 90% 350x350mm	ø0.15mm

Sleeve Head						
NF-DB02	100	250	450	R25	White 90% 350x350mm	ø0.15mm
NF-DM03	30	50	120	R15	White 90% 350x350mm	ø0.15mm
NF-DT02	5	15	40	R4	White 90% 350x350mm	ø0.15mm
NF-DT04	15	40	70	R4	White 90% 350x350mm	ø0.15mm
NF-DT05	30	60	100	R15	White 90% 350x350mm	ø0.15mm
NF-DR05	5	15	40	R4	White 90% 350x350mm	ø0.15mm
NF-DK22	50	120	250	R15	White 90% 350x350mm	ø0.15mm
NF-DK43	12	60	100	R15	White 90% 350x350mm	ø0.15mm

Side View						
NF-DV01	50	120	200	R25	White 90% 350x350mm	ø0.025mm
NF-DV02	7	30	80	R15	White 90% 350x350mm	ø0.015mm
NF-DV03	50	120	200	R25	White 90% 350x350mm	ø0.025mm
NF-DK33	50	120	200	R25	White 90% 350x350mm	ø0.025mm

Liquid Detection						
NF-DF01/DF03	-	-	-	R60	Clear liquid	-
NF-DF02	-	-	-	R60	Cloudy liquid	-

Heat resistance						
NF-DH01 (180°C)	150	250	450	R35	White 90% 350x350mm	ø0.15mm
NF-DH02 (100°C)	50	150	250	R25	White 90% 350x350mm	ø0.15mm
NF-DH83 (300°C)	100	200	300	R25	White 90% 350x350mm	ø0.15mm

Fluorescesin						
NF-DY01	50	70	100	R60	-	ø0.02mm

Limited Range						
NF-DC02	6mm	6mm	6mm	R15	-	ø0.015mm

## Thru-Beam Type

Type	Distance on Response			Radius	Object	
	60µs	250µs	2ms		Regular	Minimum

Standard						
NF-TS07	450	800	1800	R30	ø1mm	ø0.5mm
NF-TB01	450	800	1800	R30	ø1mm	ø0.5mm
NF-TB01-10	300	500	1000	R30	ø1mm	ø0.5mm
NF-TB02	250	500	1000	R25	ø1mm	ø0.2mm

Super Flexible						
NF-TK05	200	400	800	R2	ø1mm	ø0.2mm
NF-TK77	200	400	800	R2	ø1mm	ø0.2mm

Flexible						
NF-TR01	250	400	800	R4	ø1mm	ø0.3mm
NF-TR02	90	200	350	R4	ø0.5mm	ø0.1mm
NF-TR03/TR03-2	90	200	350	R4	ø0.5mm	ø0.1mm

Sleeve Head						
NF-TB03	250	600	1000	R25	ø1mm	ø0.2mm
NF-TT01	20	40	80	-	ø0.25mm	ø0.1mm
NF-TK75	70	150	300	R15	ø0.5mm	ø0.1mm

Side View						
NF-TV01	200	400	800	R25	ø1mm	ø0.2mm
NF-TV02	60	150	200	R15	ø0.5mm	ø0.1mm
NF-TV04	60	150	200	R15	ø0.5mm	ø0.1mm
NF-TS08	200	400	800	R25	ø0.1mm	ø0.2mm
NF-TS12	2000	3000	4000	R25	ø1.2mm	ø0.5mm
NF-TK34	200	400	800	R25	ø0.1mm	ø0.2mm
NF-TK16	2000	3000	4000	R25	ø0.1mm	ø0.2mm

Array Head						
NF-TS10	250	500	800	R25	ø1.5mm	ø1mm
NF-TS14	250	500	800	R25	ø1.5mm	ø0.5mm

Heat Resistance						
NF-TH01 (100°C)	200	400	700	R25	ø1mm	ø0.2mm
NF-TH02 (180°C)	350	700	1000	R35	ø1.5mm	ø0.5mm
NF-TH84 (300°C)	200	400	800	R25	ø1mm	ø0.2mm

Fluorescesin						
NF-TY01	1200	2500	3500	R60	ø2mm	ø0.3mm
NF-TY02	400	800	1500	R60	ø2mm	ø0.3mm

Small Head						
NF-TM01	250	500	1000	R25	ø1mm	ø0.2mm
NF-TM02	90	200	350	R15	ø0.5mm	ø0.1mm
NF-TM03	90	200	350	R15	ø0.5mm	ø0.1mm

## Thru-Beam with Extension Lens

Type	Distance on Response			Object	
	60µs	250µs	2ms	Regular	Minimum

NF-TB01 with NF-TA01	1500	3500	4000	-	ø3mm
NF-TB01-10 with NF-TA01	1000	2500	4000	-	ø3mm
NF-TB02 with NF-TA01	3000	4000	4000	-	ø3mm
NF-TR01 with NF-TA01	3000	4000	4000	-	ø3mm
NF-TH01 with NF-TA01	2500	3500	4000	-	ø3mm
NF-TK77 with NF-TA01	3000	4000	4000	-	ø3mm

Side View Lens						
NF-TB01 with NF-TA02	400	800	1500	-	ø3mm	
NF-TB01-10 with NF-TA02	300	600	1000	-	ø3mm	
NF-TB02 with NF-TA02	450	1000	1500	-	ø3mm	
NF-TR01 with NF-TA02	450	700	1000	-	ø3mm	
NF-TH01 with NF-TA02	450	800	1000	-	ø3mm	
NF-TK77 with NF-TA02	450	800	1500	-	ø3mm	

# D2GF Sensing Distance

## Diffuse Reflective Type

Type	Distance on Response			Radius	Object	
	60µs	250µs	2ms		Regular	Minimum

Standard						
NF-DM01	40	80	160	R25	White 90% 350x350mm	ø0.15mm
NF-DT03	6	15	30	R15	White 90% 350x350mm	ø0.15mm
NF-DS06	6	15	30	R15	White 90% 350x350mm	ø0.15mm
NF-DK06	40	80	160	R25	White 90% 350x350mm	ø0.15mm
NF-DK04	40	80	160	R25	White 90% 350x350mm	ø0.15mm

Coaxial						
NF-DB01	30	70	100	R25	White 90% 350x350mm	ø0.15mm
NF-DB03	25	60	100	R25	White 90% 350x350mm	ø0.15mm
NF-DB01-10	20	50	80	R25	White 90% 350x350mm	ø0.15mm
NF-DT01	6	20	40	R15	White 90% 350x350mm	ø0.15mm
NF-DM02	6	20	40	R15	White 90% 350x350mm	ø0.15mm
NF-DK23	30	70	100	R25	White 90% 350x350mm	ø0.15mm
NF-DK21	4	7	15	R15	White 90% 350x350mm	ø0.15mm

Super Flexible						
NF-DK66	20	45	80	R2	White 90% 350x350mm	ø0.15mm
NF-DK67	20	45	80	R2	White 90% 350x350mm	ø0.15mm
NF-DK04Z	20	45	80	R2	White 90% 350x350mm	ø0.15mm
NF-DK63Z	20	45	80	R2	White 90% 350x350mm	ø0.15mm

Flexible						
NF-DR01	30	50	100	R4	White 90% 350x350mm	ø0.15mm
NF-DR02	3					